

new

HAMBURGATRICE - POLPETTATRICE HAMBURGER - MEATBALL FORMER



**Patent
Pending**

MACCHINA FORMATRICE DI HAMBURGER, CON POLPETTATRICE INTEGRATA

- Vetrina, Vasca e coperchio in acciaio Inox
- Struttura in acciaio Inox
- Macchina su carrello integrato dotata di ruote autofrenanti
- Funzione di stratificatore (per Hamburger)
- Altezza utile di stratificazione: 80 mm
- Pulizia filo automatico di serie
- Gruppo pale a smontaggio rapido
- Dotazione standard: Variatori di velocità (per Hamburger e Polpetta)
- Dispositivo interfogliatore - Oliatore (per polpetta)

HAMBURGER FORMING MACHINE WITH BUILT-IN MEATBALL FORMING MACHINE

- Stainless steel hopper, frontal door and lid
- Stainless steel structure
- Machine on trolley with self-braking wheels
- Stacking function (for hamburgers) - Useful stacking height: 80 mm
- Automatic Scraper Device
- Shaft assembly easily removable and changeable
- Standard equipment: Speed variators (for Hamburgers and Meatballs)
- Paper Interleaver Device - Oil feeder (for meatballs)

RECONSTITUEUSE POUR HAMBURGER, AVEC DISPOSITIF POUR BOULETTES INTÉGRÉ

- Vitrine, tremie et couvercle en acier inox
- Structure en acier inox
- Machine sur chariot intégré doté de roues auto-freinées
- Fonction de stratification (pour hamburgers)
- hauteur utile de stratification: 80 mm
- Nettoyage automatique du fil racloir
- Groupe pales à démontage rapide
- Equipement standard: Variateur de vitesse pour hamburgers et boulettes
- distributeur automatique de papier - burette d'huile (pour boulettes)

HAMBURGER-MASCHINE MIT INTEGRIERTER FLEISCHKLOSS-MASCHINE

- Vitrine, Fülltrichter, und Deckel aus Inox-Stahl
- Aufbau aus Inox-Stahl
- Maschine auf integriertem Wagen mit selbstbremsenden Rädern
- Schichtfunktion (für Hamburger)- nutzbare Höhe für schichten: 80 mm
- Automatische Reinigung des Drahtabstreifers
- Mischschaufe mit Schnellausbauvorrichtung
- Standardausrüstung: Drehzahlregelungen für Hamburgers und Fleischklöße
- Rennblatteinleger - Integrierter Oler (für Fleischklöße)

MÁQUINA DE HAMBURGUESAS CON DISPOSITIVO PARA ALBÓNDIGAS INTEGRADO

- Puerta frontal, cuba y tapa de acero inoxidable
- Estructura de acero inoxidable
- Máquina portante, dotada de ruedas autofrenantes
- Función de estratificador (para hamburguesas) - Altura útil de apilado: 80 mm
- Limpieza automática del hilo separador
- Ensamblaje palas de desmontaje rápido
- De serie con la máquina: variador de velocidad (para hamburguesas y albóndigas) - Dispositivo colocador de papel - Dosificador de aceite (para albóndigas)



Patent Pending

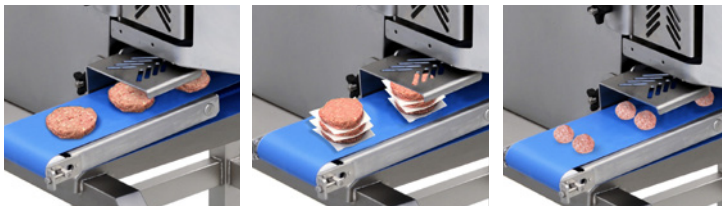

CARATTERISTICHE TECNICHE - TECHNICAL SPECIFICATIONS - TECHNISCHE DATEN - CARACTÉRISTIQUES - ESPECIFICACIONES

		C/E HF
Alimentazione - Power supply - Alimentation - Versorgung - Alimentación	V./Hz	230/1/50
Potenza assorbita - Power input - Puissance absorbée - Aufgenommene Leistung - Potencia absorbida	kW (HP)	0,9 (1,2)
Capacità vasca - Hopper capacity - Capacité tremie - Fassungsvermögen - Fülltrichter - Capacidad cuba	l	40
HAMBURGERS/PATTIES Produzione max. - Max. output - Production max. - Produktion max. - Máx producción (*)	hamburgers/h	~ 3000
POLPETTE/ MEATBALLS Produzione max. - Max. output - Production max. - Produktion max. - Máx producción (**)	meatballs/h (**)	~ 6000
Peso netto - Net weight - Poids net - Nettogewicht - Peso neto	kg	160

(*) Approssimativo, a seconda dell'impasto - Approximate, depending on the mixture - Approximatif, selon le type de pâte - ungefähr, je nach Teig - Aproximativo, según la mezcla

(**) Considerando formato doppio - Considering double size - Pour un format double - unter Berücksichtigung des Doppelformats - Considerando el formato doble

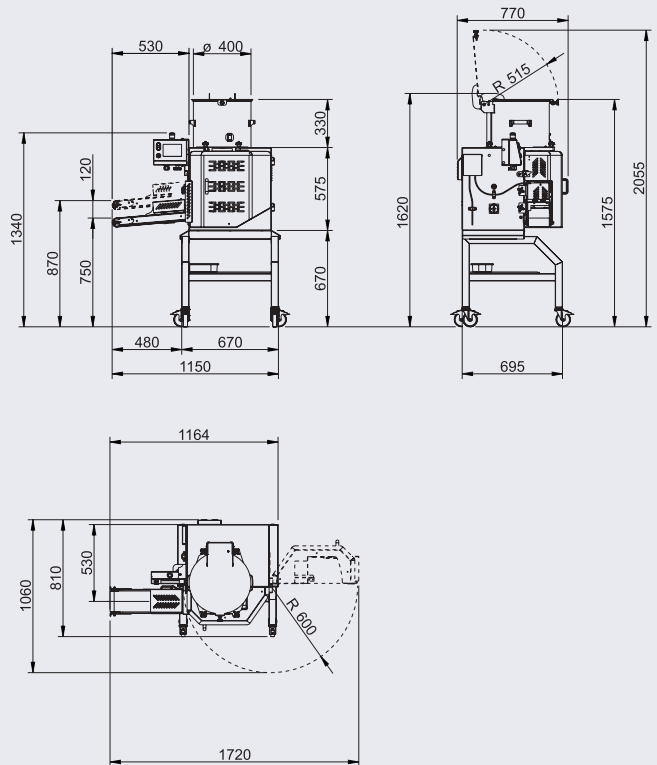

HAMBURGER PATTY

DIMENSIONI DIMENSIONS

POLPETTE MEATBALLS

DIMENSIONI DIMENSIONS



Max. Ø 135 mm
(spessore max/
max thickness: 30 mm)



Min. Ø 25 mm
Max. Ø 39 mm



Macchina conforme alle norme CE in materia di igiene e di sicurezza.

The machine complies with CE standards in terms of hygiene and safety.